

# Product datasheet

## Captair 392 Smart

Ductless filtering fume hoods

### Safer to operate

- Erlab Exclusive filtration technology combining activated carbon and HEPA/ULPA to adapt to the manipulation
- AFNOR Meets NFX 15 211/ANSI Z9.5-2012 filtration efficiency standard (class 1 and 2)
- Real time sensors to detect main filter saturation with solvents, acids or formaldehyde
- Safety filter in case of main filter saturation
- Air face velocity permanent monitoring
- Erlab Safety Program: application analysis and validation, usage framework certification, usage follow-up
- Connected device allowing reception of safety notifications and use status

### Simpler to use

Real time status communication by light and sound pulses:

- Air face velocity decrease
- Main filter saturation
- Fan failure
- Excess scheduled working time

### Flexibility

- Modular filtration column adapting to application changes
- Easy and fast relocation

### Savings

- No ductwork cost
- Deliver energy savings
- Compared to an extraction fume cupb energy savings compensate filter replacement cost

### Environment

- No chemical release into the atmosphere
- Low energy consumption



Dimensions(mm)

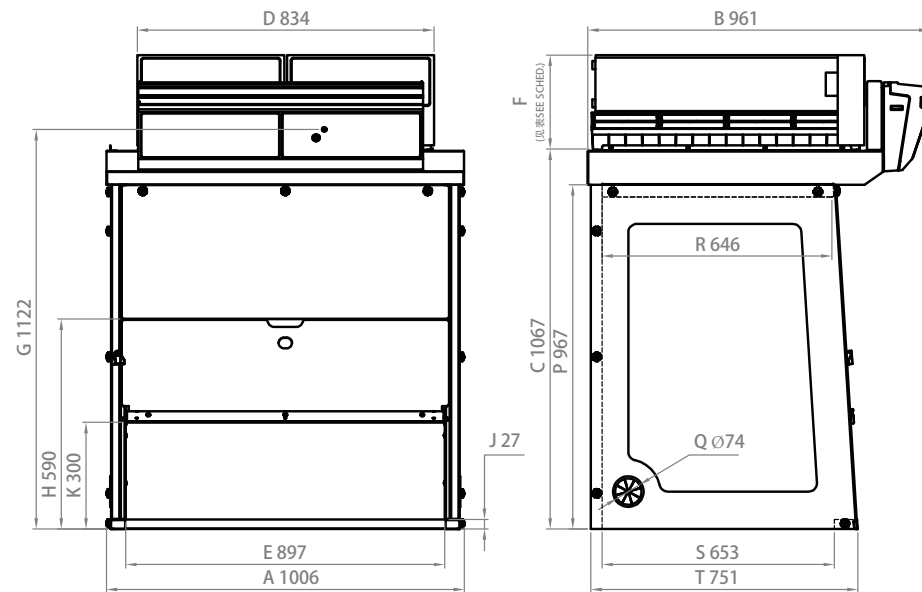

SYMBOL	DESCRIPTION
A	Overall width
B	Overall depth
C	Filter installation height
D	Width of (2) filtration columns
E	Internal width of hood
F	Filter height*
G	Height of button
H	Maximum opening height of sash
J	Height of armrest bar
K	Opening height of reverso sash
P	Internal height of hood
Q	Passing through diameter of cable port
R	Internal depth of hood - top
S	Internal depth of hood - bottom
T	Depth of hood

Heights according to the filtration column configuration		
Type 1C or 1P	1333 mm	Please add 150mm between the last filter and the ceiling to allow a good air recirculation and to replace filters easily
Type 2C or 1P1C or 1C1P	1430 mm	
Type 1P2C or 1P1C1P	1515 mm	

Work surfaces with built in spill tray

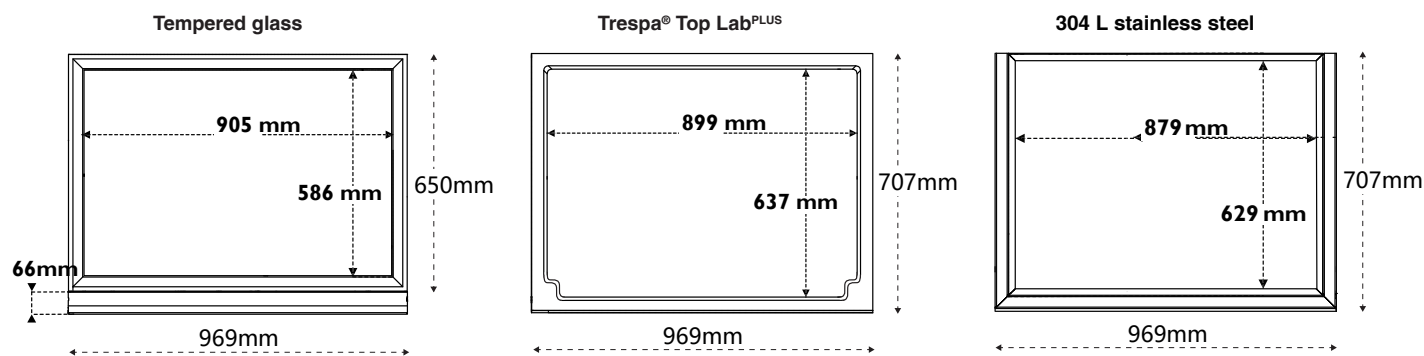

Benchcap: fixed work bench

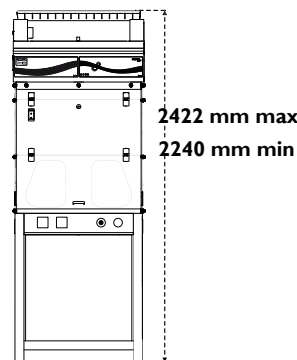

Mobicap : mobile rolling cart

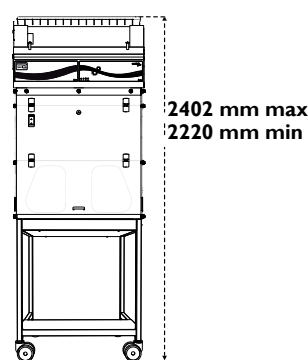

Modular design of the filtration column allows to adapt to every protection needs

Customized filtration column	Products handled / Applications			
	Liquid chemicals handlings	Powders handlings	Liquid chemicals and powders handlings	Liquid chemicals handlings in clean room
Class 1* according to the NF X 15-211		NA		
Class 2 according to the NF X 15-211				

**C** Carbon filtration for gases and vapours  
 AS:For organic vapours  
 BE+:Polyvalent for acid + organic vapours  
 F:For formaldehyde vapours  
 K:For ammonia vapours

**P** Particulate filtration for powders  
 HEPA H14:99.995 % efficiency filtration of particles over 0.1 µm in size  
 ULPA U17:99.999995 % efficiency filtration of particles over 0.1 µm in size

Ventilation  
 Molecode Automatic alarm to detect a filtration fault  
 Class 1 Maximum safety

<b>Safety Standards</b>	AFNOR NF X 15-211:2009: France - BS 7989: England DIN 12 927:Germany - EN 1822:1998 (HEPA H14 & ULPA U17 Filters) - CE Marking
<b>Air Flow</b>	440 m³/h
<b>Air Face Velocity</b>	0.4 to 0.6 m/s
<b>Voltage/Frequency</b>	100-240 V / 50-60 Hz
<b>Power consumption/ Max. amperage absorbed</b>	105 W / 1.05A
<b>Net Weight (kg)</b>	59.2kg
<b>Sash openings</b>	Ergonomic oblong holes
<b>Structure</b>	Corrosion resistant electro-galvanized steel coated with anti-acid polymer
<b>Side and front panels</b>	Chemical resistant acrylic , Poly(methyl methacrylate) (PMMA)
<b>Filtration module</b>	Polypropylene (flame retardant)

Equipment

<b>Communication interface</b>	Simple communication by audible and light pulses: unit running time, air face velocity, automatic filter saturation detection, ventilation settings, fan failure alarm
<b>Filtration technology</b>	1 column that can be configured to handle liquids, powders, or both
<b>Carbon filtration for gases and vapours</b>	Following filtration column configuration (see table above)
<b>Particulate filtration for powders</b>	Following filtration column configuration (see table above)
<b>eGuard</b>	Remote control to monitor the Smart fume hood, change the settings, and deliver safety alerts immediately.
<b>Internal lighting</b>	LED lighting >650 Lux
<b>Anemometer</b>	Air face velocity alarm
<b>Chemical Listing</b>	List of approved chemicals

Accessories

<b>Work Surfaces</b>	Trespa® Top Lab <sup>plus</sup> , Glass or 304L Stainless Steel
<b>Molecode</b>	Detection sensor for : Type S, for solvents / Type A, for acids / Type F, for formaldehyde
<b>Benches</b>	Mobile (Mobicap) or fixed (Benchcap)
<b>Bench equipment</b>	Technical gases outlets, water outlets, front control valves, sink, power sockets (Only compatible with Trespa® Top Lab <sup>plus</sup> worktop and fixed bench)
<b>Particulate Pre-filter</b>	Protects the main filter(s) from dust
<b>Transparent Back Panel</b>	Clear acrylic panel for easy viewing



# About Erlab

The Erlab Research and Development laboratory

Since 1968, **Erlab** has been a specialist, inventor and world leader in **ductless, zero-emission filtering fume hoods for laboratories** to provide total safety in chemical handling.

## 1 Erlab filtration

We provide technologies to protect laboratory staff from inhaling chemicals. This is made possible thanks to our **Research and Development (R&D) department**, which has continuously improved our filtration technology **for more than 50 years**. That's why, in 2009, we invented the **ERLAB ABOVE** label for tried and tested filtration technology.

## 2 The AFNOR NF X 15-211: 2009 standard

Erlab's filtration technology conforms to the **NFX 15-211: 2009 standard**, the industry's most demanding standard for molecular filtration, developed by a committee of independent scientists and specialized manufacturers.

**This text imposes performance criteria linked to:**

- Filtration efficiency
- Containment efficiency
- Air face velocity
- Documentation: **chemical listing**

## 3 The ESP programme

A set of three services included with the purchase of each device designed to ensure your safety.



**eValiQuest** Risk analysis – Determination of protection needs – Determination of ergonomic needs.



**ValiPass** Certified installation – Total safety for handling.



**ValiGuard** Ongoing monitoring – Preventative and maintenance inspections – Device reconfiguration based on protection needs – Development of handling.

## 4 Flex technology

The combination of molecular and particulate filtration technologies allows a single device to meet laboratories' protection needs. This innovation from Erlab's R&D department offers unprecedented **flexibility, versatility and value**. A single device can be reconfigured over time and easily reassigned to other applications.

## 5 Smart technology

Smart technology is a **simple and innovative** means of communication that improves safety. This technology uses a light and sound signal to indicate the user's level of protection. The advantages of the technology are:

- 1/ Light pulsation:** Real-time communication via LED light pulses intuitively alerts the user to the device's operating status.
- 2/ Simplicity:** One-touch activation.
- 3/ Detection system:** The exclusive detection system continuously monitors filtration performance.
- 4/ Built-in monitoring:** This service provides direct access to the **status, settings and history** of your device.

France  
+33 (0) 2 32 09 55 80 | ventes@erlab.net

United States  
+1 800-964-4434 | captairsales@erlab.com

China  
+86 (0) 512 5781 4085 | erlab-sales@erlab.net

Spain  
+34 936 732 474 | export.south@erlab.net

Germany  
0800 330 47 31 | export.north@erlab.net

United Kingdom  
+44 (0) 1722 341 940 | export.north@erlab.net

Italy  
+39 (0) 2 89 00 771 | export.south@erlab.net



[www.erlab.com/apac/](http://www.erlab.com/apac/)

ecosystem