

Product datasheet

Captair 633 Smart

Ductless filtering fume hoods

Safer to operate

- Erlab Exclusive filtration technology combining activated carbon and HEPA/ULPA to adapt to the manipulation
- AFNOR Meets NFX 15 211/ANSI Z9.5-2012 filtration efficiency standard (class 1 and 2)
- Real time sensors to detect main filter saturation with solvents, acids or formaldehyde
- Safety filter in case of main filter saturation
- Air face velocity permanent monitoring
- Erlab Safety Program: application analysis and validation, usage framework certification, usage follow-up
- Connected device allowing reception of safety notifications and use status

Simpler to use

Real time status communication by light and sound pulses:

- Air face velocity decrease
- Main filter saturation
- Fan failure
- Excess scheduled working time

Flexibility

- Modular filtration column adapting to application changes
- Easy and fast relocation

Savings

- No ductwork cost
- Deliver energy savings
- Compared to an extraction fume cupboard, energy savings compensate filter replacement cost

Environment

- No chemical release into the atmosphere
- Low energy consumption



Dimensions(mm)

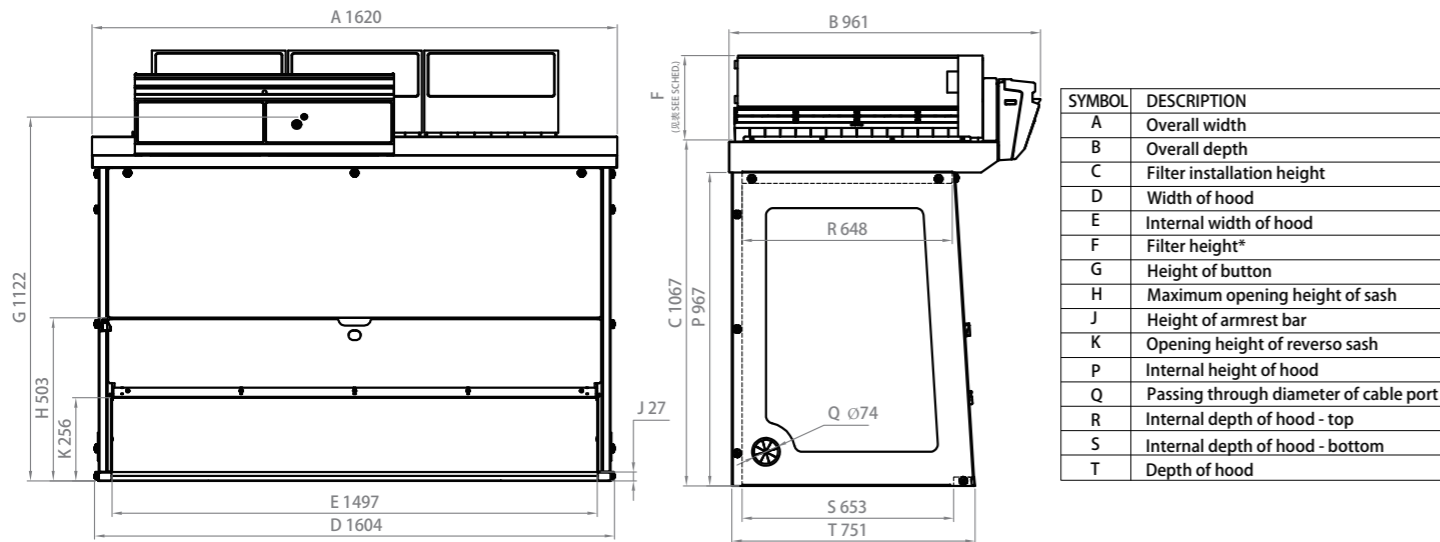

Heights according to the filtration column configuration		
Type 1C or 1P	1333 mm	Please add 150mm between the last filter and the ceiling to allow a good air recirculation and to replace filters easily
Type 2C or 1P1C or 1C1P	1430 mm	
Type 1P2C or 1P1C1P	1515 mm	

Work surfaces with built in spill tray

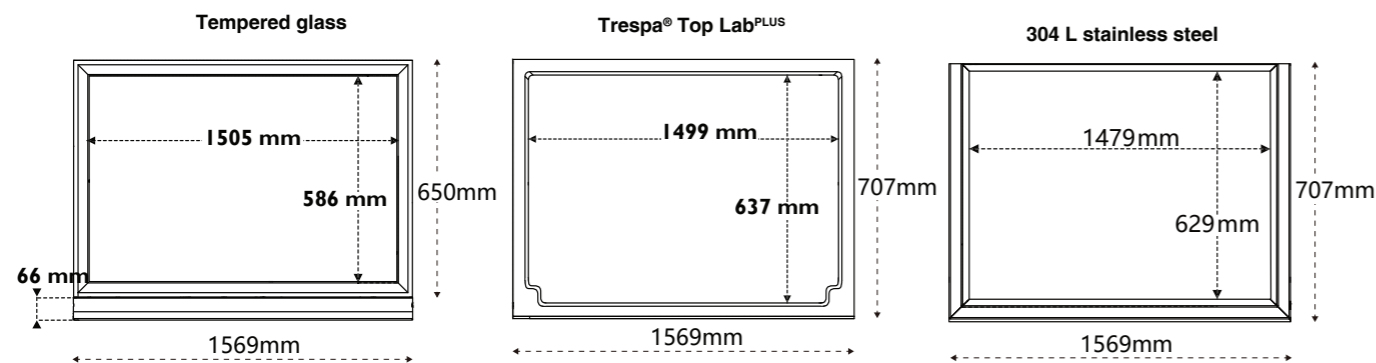

Benchcap: fixed work bench

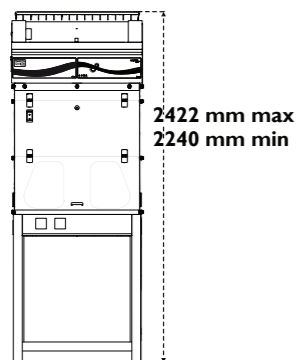

Modular design of the filtration column allows to adapt to every protection needs

Customized filtration column	Products handled / Applications			
	Liquid chemicals handlings	Powders handlings	Liquid chemicals and powders handlings	Liquid chemicals handlings in clean room
Class 1* according to the NF X 15-211		NA		
Class 2 according to the NF X 15-211				

C Carbon filtration for gases and vapours
 AS:For organic vapours
 BE+:Polyvalent for acid + organic vapours
 F:For formaldehyde vapours
 K:For ammonia vapours

P Particulate filtration for powders
 HEPA H14:99.995 % efficiency filtration of particles over 0.1 µm in size
 ULPA U17:99.999995 % efficiency filtration of particles over 0.1 µm in size

Ventilation
 Molecode Automatic alarm to detect a filtration fault
 Class 1 = Maximum safety

Safety Standards	AFNOR NF X 15-211:2009: France - BS 7989: England DIN 12 927:Germany - EN 1822:1998 (HEPA H14 & ULPA U17 Filters) - CE Marking
Air Flow	660 m³/h
Air Face Velocity	0.4 to 0.6 m/s
Voltage/Frequency	100-240 V / 50-60 Hz
Power consumption/Max. amperage absorbed	160 W / 1.6A
Net Weight (kg)	80.9kg
Sash openings	Ergonomic oblong holes
Structure	Corrosion resistant electro-galvanized steel coated with anti-acid polymer
Side and front panels	Chemical resistant acrylic , Poly(methyl methacrylate) (PMMA)
Filtration module	Polypropylene (flame retardant)

Equipment

Communication interface	Simple communication by audible and light pulses: unit running time, air face velocity, automatic filter saturation detection, ventilation settings, fan failure alarm
Filtration technology	1 column that can be configured to handle liquids, powders, or both
Carbon filtration for gases and vapours	Following filtration column configuration (see table above)
Particulate filtration for powders	Following filtration column configuration (see table above)
eGuard	Remote control to monitor the Smart fume hood, change the settings, and deliver safety alerts immediately.
Internal lighting	LED lighting >650 Lux
Anemometer	Air face velocity alarm
Chemical Listing	List of approved chemicals

Accessories

Work Surfaces	Trespa® Top Lab ^{plus} , Glass or 304L Stainless Steel
Molecode	Detection sensor for : Type S, for solvents / Type A, for acids / Type F, for formaldehyde
Benches	Mobile (Mobicap) or fixed (Benchcap)
Bench equipment	Technical gases outlets, water outlets, front control valves, sink, power sockets (Only compatible with Trespa® Top Lab ^{plus} worktop and fixed bench)
Particulate Pre-filter	Protects the main filter(s) from dust
Transparent Back Panel	Clear acrylic panel for easy viewing



About Erlab

The Erlab Research and Development laboratory

Since 1968, **Erlab** has been a specialist, inventor and world leader in **ductless, zero-emission filtering fume hoods for laboratories** to provide total safety in chemical handling.

1 Erlab filtration

We provide technologies to protect laboratory staff from inhaling chemicals. This is made possible thanks to our **Research and Development (R&D) department**, which has continuously improved our filtration technology **for more than 50 years**. That's why, in 2009, we invented the **ERLAB ABOVE** label for tried and tested filtration technology.

2 The AFNOR NF X 15-211: 2009 standard

Erlab's filtration technology conforms to the **NFX 15-211: 2009 standard**, the industry's most demanding standard for molecular filtration, developed by a committee of independent scientists and specialized manufacturers.

This text imposes performance criteria linked to:

- Filtration efficiency
- Containment efficiency
- Air face velocity
- Documentation: **chemical listing**

3 The ESP programme

A set of three services included with the purchase of each device designed to ensure your safety.



eValiQuest Risk analysis – Determination of protection needs – Determination of ergonomic needs.



ValiPass Certified installation – Total safety for handling.



ValiGuard Ongoing monitoring – Preventative and maintenance inspections – Device reconfiguration based on protection needs – Development of handling.

4 Flex technology

The combination of molecular and particulate filtration technologies allows a single device to meet laboratories' protection needs. This innovation from Erlab's R&D department offers unprecedented **flexibility, versatility and value**. A single device can be reconfigured over time and easily reassigned to other applications.

5 Smart technology

Smart technology is a **simple and innovative** means of communication that improves safety. This technology uses a light and sound signal to indicate the user's level of protection. The advantages of the technology are:

1/ Light pulsation: Real-time communication via LED light pulses intuitively alerts the user to the device's operating status.

2/ Simplicity: One-touch activation.

3/ Detection system: The exclusive detection system continuously monitors filtration performance.

4/ Built-in monitoring: This service provides direct access to the **status, settings and history** of your device.

France
+33 (0) 2 32 09 55 80 | ventes@erlab.net

United States
+1 800-964-4434 | captairsales@erlab.com

China
+86 (0) 512 5781 4085 | erlab-sales@erlab.net

Spain
+34 936 732 474 | export.south@erlab.net

Germany
0800 330 47 31 | export.north@erlab.net

United Kingdom
+44 (0) 1722 341 940 | export.north@erlab.net

Italy
+39 (0) 2 89 00 771 | export.south@erlab.net



www.erlab.com/apac/

ecosystem