



## Product datasheet

---

# Captair Flow 483 Smart

Mobile ductless filtering clean air enclosure

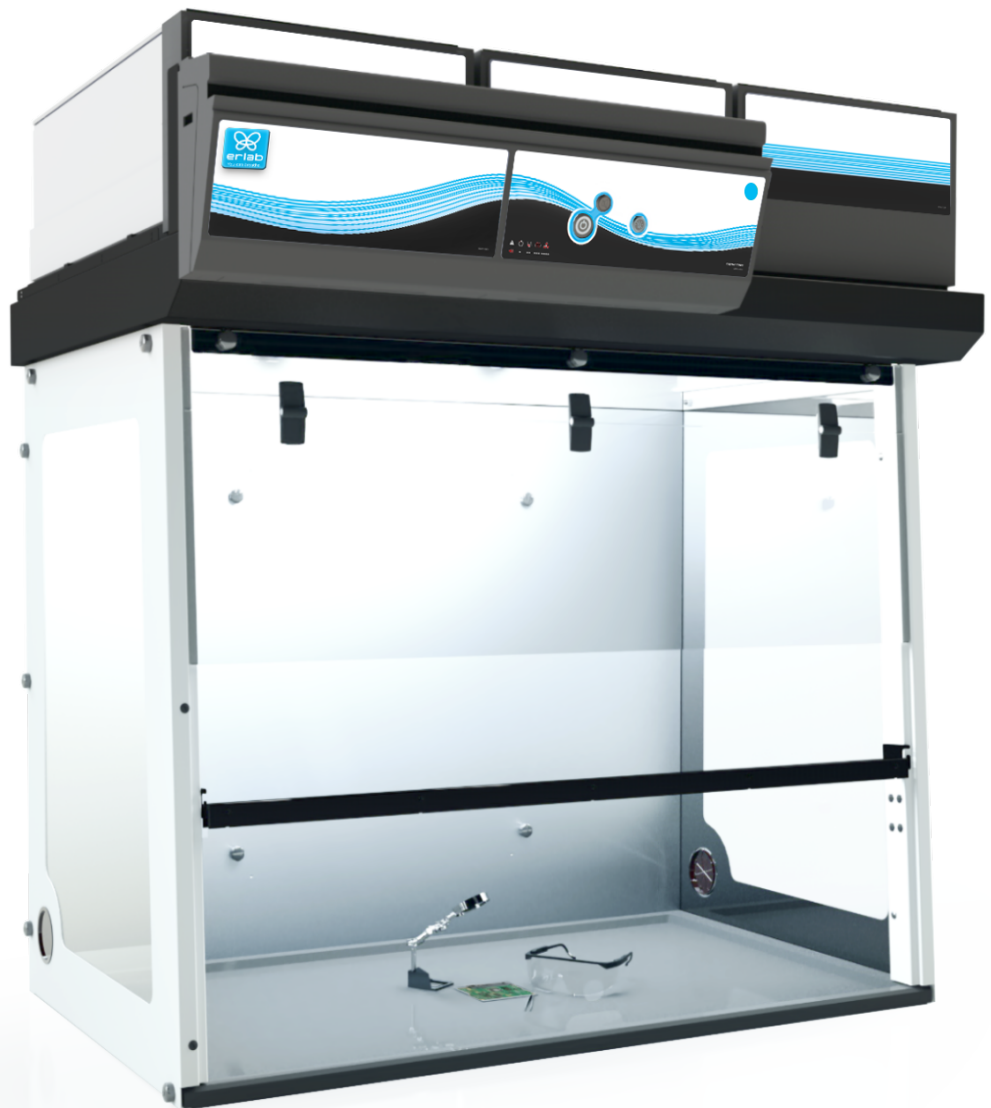

1P

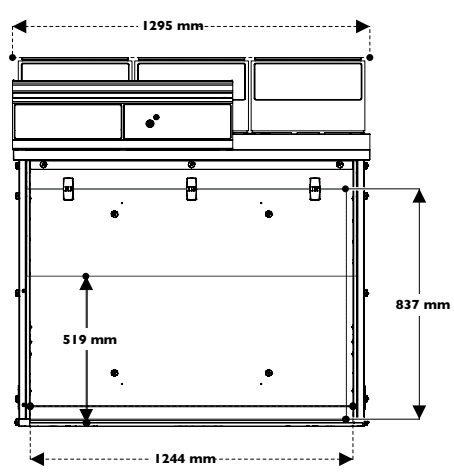

1C1P

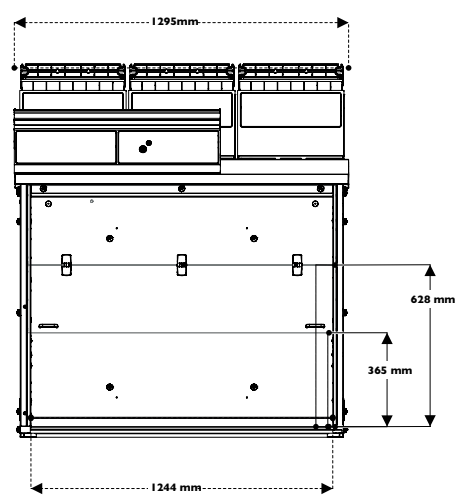

1P / 1C1P

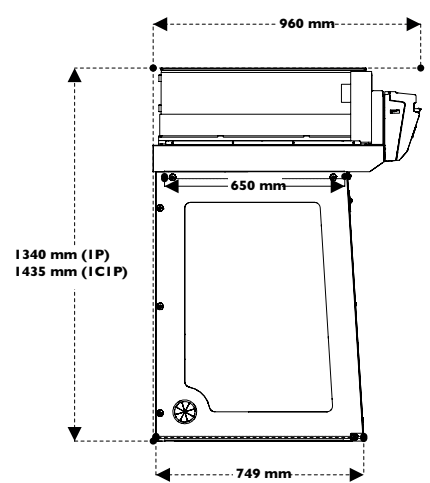

Please add 150mm between the last filter and the ceiling to allow good air recirculation and to replace filters easily.

Work surfaces with built-in spill tray

Trespa® Top Lab<sup>PLUS</sup>

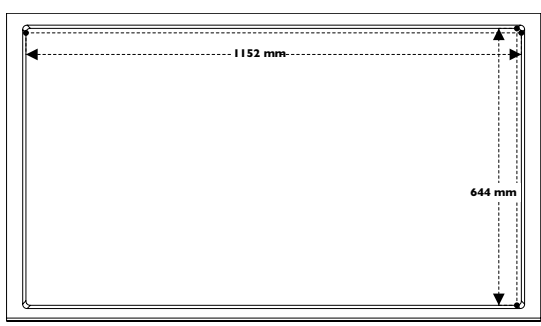

Inox 304L

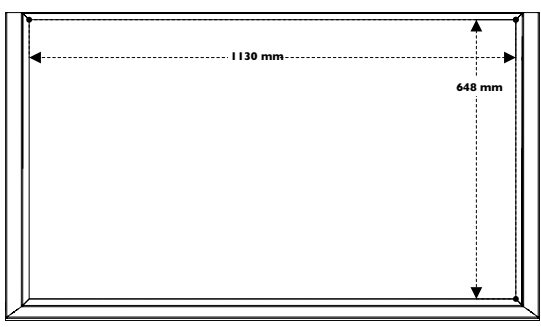

Benchcap: Fixed work bench

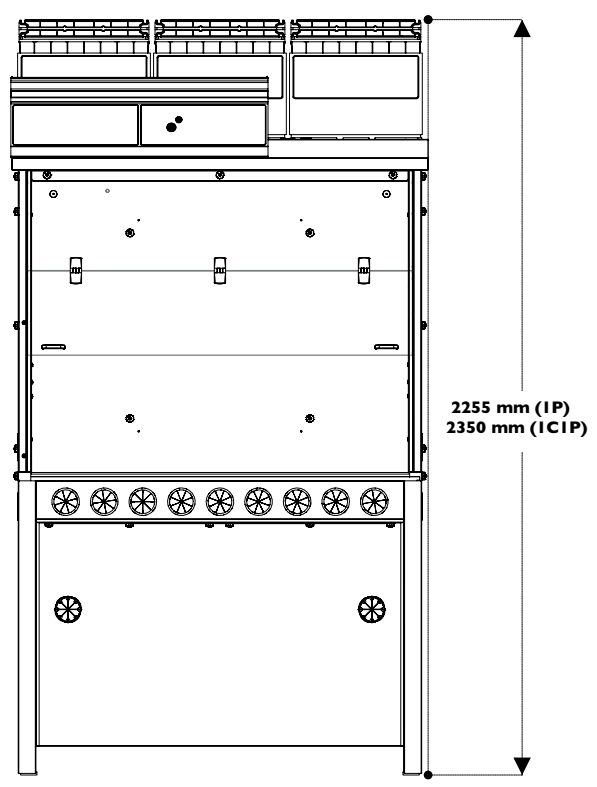

FILTRATION TECHNOLOGY



Our filtration column can be configured for your specific application requirements.

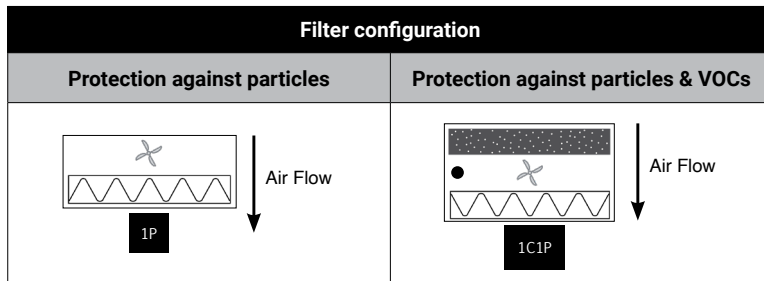

### Filter types:

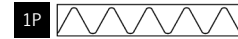

Particulate filtration for powders



Carbon filtration for gases and vapours

 Ventilation    ● Molecode : Automatic alarm to detect filter breakthrough

Model	1P	1C1P
Safety standards	NF EN 61010 – EU Marking – EN 1822: 1998 (HEPA H14 & ULPA U16 Filters) Air quality within the enclosure: ISO Class 5 EN 14644-1 standard	
Voltage/Frequency	110-230V/50-60Hz	
Air face velocity	0.35m/s / 69fpm	
Air flow	770m <sup>3</sup> /h / 453CFM	530m <sup>3</sup> /h / 312CFM
Power consumption	95W	90W
Decibel level	60dBA	57dBA
Side and front panels	Chemical resistant acrylic	
Structure	Corrosion resistant electro-galvanized steel coated with antiacid polymer	
Filtration module	Polypropylene	

### Filtration

Particulate filter (1P)	HEPA H14: This filtration technology traps particles larger than 0.1µm with 99.995% efficiency according to the MPPS method set forth in the EN 1822-1 standard. ULPA U16: This filtration technology traps particles larger than 0.1µm with 99.9995% efficiency according to the MPPS method set forth in the EN 1822-1 standard.
Carbon filter (1C) (optional)	Adding a carbon filter to your enclosure allows protection of your samples from VOCs. AS filter: For organic vapours
Particulate prefilter	Protects particulate filters from dust contained in the laboratory environment (only for 1P version)

### Features

Worktop	Stainless steel 304L / TRESPA® Top Lab <sup>PLUS</sup>
Internal lighting	LED – IP44 – 6000K
	950lux
Monitoring	Real-time control of security settings
Monitoring of ambient manipulation conditions	Particles measuring system
Connectivity	RJ45 cable connection to view and change workstation settings (cable included)
Anemometer	Monitors a drop in pressure that indicates prefilter or filter replacement is required
Side panel utility ports	To allow electrical cables and/or fluid lines to enter the enclosure with ease – 2 per unit
Ceiling lighting	ON/OFF light button

### Accessories

Benches	Rolling cart (Mobicap) or Fixed bench (Benchcap)
Shelves	Internal metal sliding shelf (only for Benchcap)
Molecode S	Automatic detection of VOC filter breakthrough



The ERLAB Research and Development Laboratory

# About ERLAB

Since 1968, **ERLAB** has been a specialist, inventor and world leader in **ductless, zero-emission filtering fume hoods for laboratories** to provide total safety in chemical handling.

## 1 ERLAB filtration

We provide technologies to protect laboratory staff from inhaling chemicals. This is made possible thanks to our **Research and Development (R&D) department**, which has continuously improved our filtration technology **for more than 50 years**. That's why, in 2009, we invented the **ERLAB ABOVE** label for tried and tested filtration technology.

## 2 The AFNOR NF X15-211: 2009 standard

ERLAB's filtration technology conforms to the **NF X15-211: 2009 standard**, the industry's most demanding standard for molecular filtration, developed by a committee of independent scientists and specialized manufacturers.

**This text imposes performance criteria linked to:**

- Filtration efficiency
- Containment efficiency
- Air face velocity
- Documentation: **chemical listing**

## 3 The ESP programme

A set of three services included with the purchase of each device designed to ensure your safety.



**eValiQuest** Risk analysis – Determination of protection needs – Determination of ergonomic needs



**ValiPass** Certified installation – Total safety for handling



**ValiGuard** Ongoing monitoring – Preventative and maintenance inspections – Device reconfiguration based on protection needs – Development of handling

## 4 Flex technology

The combination of molecular and particulate filtration technologies allows a single device to meet laboratories' protection needs. This innovation from ERLAB's R&D department offers unprecedented **flexibility, versatility and value**. A single device can be reconfigured over time and easily reassigned to other applications.

## 5 Smart technology

Smart technology is a **simple and innovative** means of communication that improves safety. This technology uses a light and sound signal to indicate the user's level of protection. The advantages of the technology are:

- 1 | **Light pulsation:** Real-time communication via **LED light pulses** intuitively alerts the user to the device's operating status.
- 2 | **Simplicity:** One-touch activation.
- 3 | **Detection system:** The exclusive detection system continuously monitors filtration performance.
- 4 | **Built-in monitoring:** This service provides direct access to the **status, settings and history** of your device.

**France**  
+33 (0) 2 32 09 55 80 | ventes@erlab.net

**United States**  
+1 800-964-4434 | captainsales@erlab.com

**China**  
+86 (0) 512 5781 4085 | sales.china@erlab.com.cn

**Spain**  
+34 936 732 474 | export.south@erlab.net

**Germany**  
0800 330 47 31 | export.north@erlab.net

**United Kingdom**  
+44 (0) 1722 341 940 | export.north@erlab.net

**Italy**  
+39 (0) 2 89 00 771 | export.south@erlab.net



[www.erlab.com](http://www.erlab.com)

**ecosystem**